



Barrier Gate

User Manual

© 2023 Hangzhou Hikvision Digital Technology Co., Ltd. All rights reserved.

ALL RIGHTS RESERVED.

This Manual is the property of Hangzhou Hikvision Digital Technology Co., Ltd. or its affiliates (hereinafter referred to as “Hikvision”), and it cannot be reproduced, changed, translated, or distributed, partially or wholly, by any means, without the prior written permission of Hikvision. Unless otherwise expressly stated herein, Hikvision does not make any warranties, guarantees or representations, express or implied, regarding to the Manual, any information contained herein.

About this Manual

The Manual includes instructions for using and managing the Product. Pictures, charts, images and all other information hereinafter are for description and explanation only. The information contained in the Manual is subject to change, without notice, due to firmware updates or other reasons. Please find the latest version of this Manual at the Hikvision website (<https://www.hikvision.com/>).

Please use this Manual with the guidance and assistance of professionals trained in supporting the Product.

Trademarks Acknowledgement

- **HIKVISION** and other Hikvision’s trademarks and logos are the properties of Hikvision in various jurisdictions.
- Other trademarks and logos mentioned are the properties of their respective owners.

Legal Disclaimer

TO THE MAXIMUM EXTENT PERMITTED BY APPLICABLE LAW, THIS MANUAL AND THE PRODUCT DESCRIBED, WITH ITS HARDWARE, SOFTWARE AND FIRMWARE, ARE PROVIDED “AS IS” AND “WITH ALL FAULTS AND ERRORS”. HIKVISION MAKES NO WARRANTIES, EXPRESS OR IMPLIED, INCLUDING WITHOUT LIMITATION, MERCHANTABILITY, SATISFACTORY QUALITY, OR FITNESS FOR A PARTICULAR PURPOSE. THE USE OF THE PRODUCT BY YOU IS AT YOUR OWN RISK. IN NO EVENT WILL HIKVISION BE LIABLE TO YOU FOR ANY SPECIAL, CONSEQUENTIAL, INCIDENTAL, OR INDIRECT DAMAGES, INCLUDING, AMONG OTHERS, DAMAGES FOR LOSS OF BUSINESS PROFITS, BUSINESS INTERRUPTION, OR LOSS OF DATA, CORRUPTION OF SYSTEMS, OR LOSS OF DOCUMENTATION, WHETHER BASED ON BREACH OF CONTRACT, TORT (INCLUDING NEGLIGENCE), PRODUCT LIABILITY, OR OTHERWISE, IN CONNECTION WITH THE USE OF THE PRODUCT, EVEN IF HIKVISION HAS BEEN ADVISED OF THE POSSIBILITY OF SUCH DAMAGES OR LOSS.

YOU ACKNOWLEDGE THAT THE NATURE OF INTERNET PROVIDES FOR INHERENT SECURITY RISKS, AND HIKVISION SHALL NOT TAKE ANY RESPONSIBILITIES FOR ABNORMAL OPERATION, PRIVACY LEAKAGE OR OTHER DAMAGES RESULTING FROM CYBER-ATTACK, HACKER ATTACK, VIRUS INSPECTION, OR OTHER INTERNET SECURITY RISKS; HOWEVER, HIKVISION WILL PROVIDE TIMELY TECHNICAL SUPPORT IF REQUIRED.

YOU AGREE TO USE THIS PRODUCT IN COMPLIANCE WITH ALL APPLICABLE LAWS, AND YOU ARE SOLELY RESPONSIBLE FOR ENSURING THAT YOUR USE CONFORMS TO THE APPLICABLE LAW. ESPECIALLY, YOU ARE RESPONSIBLE, FOR USING THIS PRODUCT IN A MANNER THAT DOES NOT INFRINGE ON THE RIGHTS OF THIRD PARTIES, INCLUDING WITHOUT LIMITATION, RIGHTS OF PUBLICITY, INTELLECTUAL PROPERTY RIGHTS, OR DATA PROTECTION AND OTHER PRIVACY RIGHTS.

YOU SHALL NOT USE THIS PRODUCT FOR ANY PROHIBITED END-USES, INCLUDING THE DEVELOPMENT OR PRODUCTION OF WEAPONS OF MASS DESTRUCTION, THE DEVELOPMENT OR PRODUCTION OF CHEMICAL OR BIOLOGICAL WEAPONS, ANY ACTIVITIES IN THE CONTEXT RELATED TO ANY NUCLEAR EXPLOSIVE OR UNSAFE NUCLEAR FUEL-CYCLE, OR IN SUPPORT OF HUMAN RIGHTS ABUSES.

IN THE EVENT OF ANY CONFLICTS BETWEEN THIS MANUAL AND THE APPLICABLE LAW, THE LATER PREVAILS.

Regulatory information

FCC information

Please take attention that changes or modification not expressly approved by the party responsible for compliance could void the user's authority to operate the equipment.

FCC compliance: This equipment has been tested and found to comply with the limits for a Class A digital device, pursuant to part 15 of the FCC Rules. These limits are designed to provide reasonable protection against harmful interference when the equipment is operated in a commercial environment. This equipment generates, uses, and can radiate radio frequency energy and, if not installed and used in accordance with the instruction manual, may cause harmful interference to radio communications. Operation of this equipment in a residential area is likely to cause harmful interference in which case the user will be required to correct the interference at his own expense.

FCC conditions

This device complies with part 15 of the FCC Rules. Operation is subject to the following two conditions:

1. This device may not cause harmful interference.
2. This device must accept any interference received, including interference that may cause undesired operation.

EU Conformity Statement

 This product and - if applicable - the supplied accessories too are marked with "CE" and comply therefore with the applicable harmonized European standards listed under the EMC Directive 2014/30/EU, the LVD Directive 2014/35/EU, the RoHS Directive 2011/65/EU.

 2012/19/EU (WEEE directive): Products marked with this symbol cannot be disposed of as unsorted municipal waste in the European Union. For proper recycling, return this product to your local supplier upon the purchase of equivalent new equipment, or dispose of it at designated collection points. For more information see: www.recyclethis.info



 2006/66/EC (battery directive): This product contains a battery that cannot be disposed of as unsorted municipal waste in the European Union. See the product documentation for specific battery information. The battery is marked with this symbol, which may include lettering to indicate cadmium (Cd), lead (Pb), or mercury (Hg). For proper recycling, return the battery to your supplier or to a designated collection point. For more information see: www.recyclethis.info

Industry Canada ICES-003 Compliance

This device meets the CAN ICES-3 (A)/NMB-3(A) standards requirements.

Symbol Conventions

The symbols that may be found in this document are defined as follows.

Symbol	Description
 NOTE	Provides additional information to emphasize or supplement important points of the main text.
 WARNING	Indicates a potentially hazardous situation, which if not avoided, could result in equipment damage, data loss, performance degradation, or unexpected results.
 DANGER	Indicates a hazard with a high level of risk, which if not avoided, will result in death or serious injury.

Safety Instructions

Laws and Regulations

Use of the product must be in strict compliance with the local laws and regulations. Please shut down the device in prohibited area.

Power Supply

- Use of the product must be in strict compliance with the local electrical safety regulations.
- Use the power adapter provided by qualified manufacturer. Refer to the product specification for detailed power requirements.
- It is recommended to provide independent power adapter for each device as adapter overload may cause over-heating or a fire hazard.
- Make sure that the power has been disconnected before you wire, install, or disassemble the device.
- DO NOT directly touch exposed contacts and components once the device is powered up to avoid electric shock.
- DO NOT use damaged power supply devices (e.g., cable, power adapter, etc.) to avoid electric shock, fire hazard, and explosion.
- DO NOT directly cut the power supply to shut down the device. Please shut down the device normally and then unplug the power cord to avoid data loss.
- DO NOT block the power supply equipment to plug and unplug conveniently.
- Make sure the power supply has been disconnected if the power adapter is idle.
- Make sure the device is connected to the ground firmly.

Transportation, Use, and Storage

- To avoid heat accumulation, good ventilation is required for a proper operating environment.
- Avoid lightning strike for device installation. Install a lightning arrester if necessary.

- Keep the device away from magnetic interference.
- Avoid device installation on vibratory surface or places, and avoid equipment installation on vibratory surface or places subject to shock (ignorance may cause device damage).
- DO NOT touch the heat dissipation component to avoid burns.
- DO NOT expose the device to extremely hot, cold, or humidity environments. For temperature and humidity requirements, see device specification.

Maintenance

- If smoke, odor, or noise arises from the device, immediately turn off the power, unplug the power cable, and contact the service center.
- If the device is abnormal, contact the store you purchased it or the nearest service center. DO NOT disassemble or modify the device in any way (For the problems caused by unauthorized modification or maintenance, the company shall not take any responsibility).
- Keep all wrappers after unpacking them for future use. In case of any failure occurred, you need to return the device to the factory with the original wrapper. Transportation without the original wrapper may result in damage to the device and the company shall not take any responsibility.

Table of Contents

CHAPTER 1	INTRODUCTION.....	7
1.1	PRODUCT INTRODUCTION.....	7
1.2	KEY FEATURE.....	7
1.2.1	<i>Mechanical Feature</i>	7
1.2.2	<i>Electrical Feature</i>	7
1.2.3	<i>Safety Feature</i>	8
1.3	PACKING LIST.....	8
1.4	DIRECTION.....	8
1.5	SAFETY INSTRUCTION.....	9
CHAPTER 2	INTERNAL STRUCTURE.....	10
2.1	INTERNAL STRUCTURE OVERVIEW.....	10
2.2	MACHINE CORE STRUCTURE.....	10
CHAPTER 3	WIRING.....	13
CHAPTER 4	DIMENSION.....	14
CHAPTER 5	BARRIER GATE COMPONENT.....	15
5.1	BARRIER GATE WITH STRAIGHT BOOM POLE.....	15
5.2	BARRIER GATE WITH CURVED BOOM POLE.....	16
CHAPTER 6	INSTALLATION.....	18
6.1	INSTALLATION DESCRIPTION.....	18
6.2	INSTALLATION.....	18
6.3	INSTALLATION DEBUG.....	19
CHAPTER 7	REMOTE CONTROL.....	20
7.1	BUTTON DESCRIPTION.....	20
7.1.1	<i>Independent Button</i>	20
7.1.2	<i>Button Combination</i>	20
7.2	DIP SWITCH DESCRIPTION.....	21
7.3	LIMIT POSITION LEARNING MODE DESCRIPTION.....	21
7.4	STATUS INDICATOR DESCRIPTION.....	21
7.5	REMOTE CONTROL DEBUG.....	22
CHAPTER 8	MAINTENANCE.....	24

Chapter 1 Introduction

1.1 Product Introduction

Barrier gate is the entrance and exit management device to limit motor vehicle passing. It can control the boom pole automatically via parking lot management system. Or you can control the boom pole via buttons on remote controller.

Barrier gate is widely applicable to toll station, parking lot, the entrance and exit of community and unit, etc.

1.2 Key Feature

1.2.1 Mechanical Feature

- The housing is solid, durable, and waterproof, adaptive to outdoor application.
- Integrated machine core design to guarantee stability and running accuracy.
- Equipped with 60 W integrated worm and gear transmission deceleration asynchronous motor with stable transmission, low noise, and compact structure. It supports self-lock. No impact when the rotor is locked to protect the controller and increase the service life of the controller.
- Adopts exact four-bar linkage mechanism to keep the boom pole running rapidly and stably, and release the motor load to increase the service life.
- Supports manual lock. You can rotate the hand wheel on the bottom of motor to control the boom pole manually when the power is cut off.

1.2.2 Electrical Feature

- Highly integrated system, connectable to multiple matched devices conveniently.
- Adopts rising/falling timeout protection to protect motor effectively, guaranteeing the all-weather running of the barrier gate and avoiding the abnormal damages.
- Adopts angle sensor to detect the boom pole position with high accuracy to guarantee the stable running.
- Abundant status indicators to make it convenient to use and maintain.
- Standard remote control and smart learning. Supports ten groups of remote control codes.
- Adopts magnetic core transformer to ensure the barrier gate to work stably in outdoor damping environment.
- Integrated with light, electricity, and mechanical control. Flexible and convenient operation. Safe and reliable usage.

1.2.3 Safety Feature

- Resistance rebound. If the boom pole is resistant during falling, it can rebound automatically.
- Induction anti-collision. When the boom pole is falling while the induction signal is received, the boom pole will rise automatically and keep rising during the triggering process. After the induction signal restores, the boom pole will fall automatically to guarantee safety.
- Rising signal first. When the boom pole is falling, if something emergency happens, it will rise once receiving the rising signal.
- Rubber strip anti-collision. The rubber strip on the boom pole can help to decrease damages caused by accident.

1.3 Packing List

Table 1-1 Packing List

No.	Name	Quantity
1	Barrier gate host	1
2	User manual	1
3	Certification	1
4	Accessory package	1
5	Remote controller	2
6	Key	2

1.4 Direction

The boom pole direction can be adjusted from left to right or from right to left.



Figure 1-1 Boom Pole Direction

1.5 Safety Instruction

Conform to the following instructions for your safety.

- DO NOT open the host door or cover when the device is working.
- The internal wiring of the device has been completed when leaving factory. In normal conditions, DO NOT change the wiring. Just connect to the power supply.
- Make sure the device is connected to the ground firmly.
- DO NOT place any object under the boom pole. No person is allowed to stand or move under the boom pole when it is falling.
- When the power is cut off, shut down the power supply first, and then rotate the boom pole to the vertical status with hand wheel.
- The boom pole and the spring have been matched to the best status when the device leaves factory. DO NOT increase or decrease the boom pole length or weight randomly to avoid the danger that the boom pole may lose balance. If you need to increase or decrease, contact the professionals.
- Contact the professionals to connect to peripheral IR protection equipment.

Chapter 2 Internal Structure

2.1 Internal Structure Overview

The internal structure of the barrier gate host is run by the worm and gear transmission deceleration asynchronous motor. The movement is transmitted to the main shaft via four-bar linkage mechanism. The angle sensor can detect the rotation angle of the output shaft, and locate the position of the boom pole accurately.

Refer to the figure below for the internal structure overview.

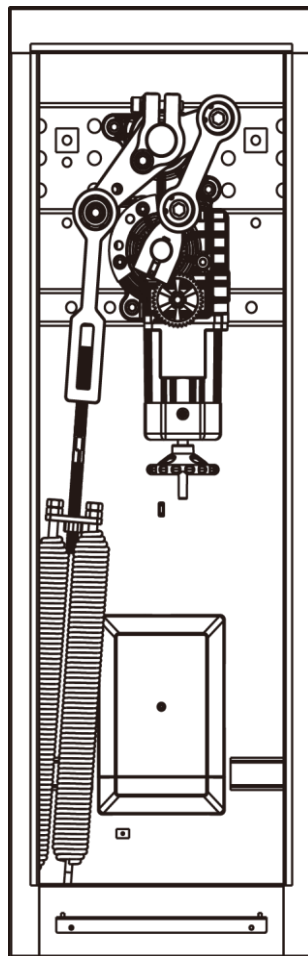

Figure 2-1 Internal Structure

2.2 Machine Core Structure

Refer to the figure below for the machine core structure.

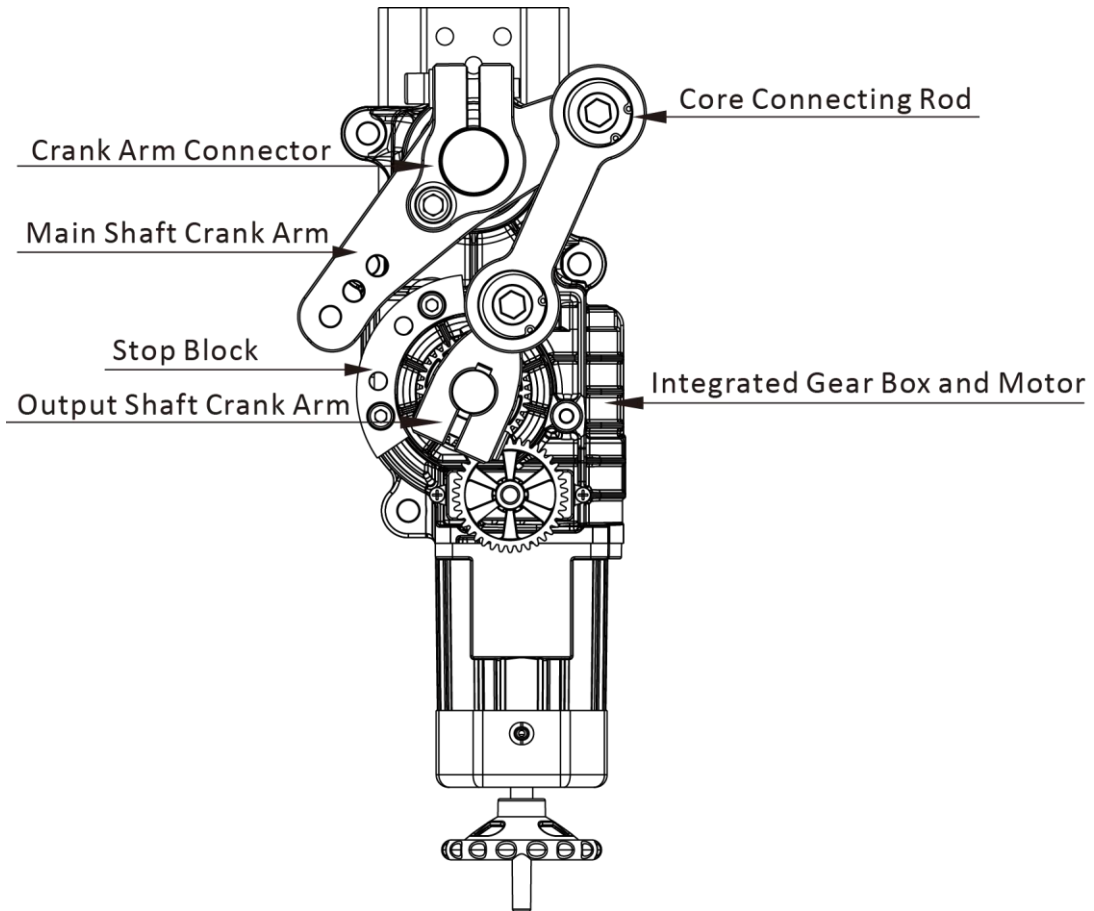

Figure 2-2 Machine Core Structure

There are extension springs installed inside the barrier gate host. During installation and debug, you can adjust the diameter and quantity of the springs according to the length of the boom pole to reach the moment balance. Refer to the table below to select the springs.

Table 2-1 Spring Description

	Boom Pole Type	Boom Pole Length Range	Hole Quantity	Spring Quantity and Type
	Non-telescopic straight boom pole	$L \leq 3 \text{ m}$	1	$2 \times \phi 4.5$
		$3 \text{ m} < L \leq 3.5 \text{ m}$	2	$2 \times \phi 4.5$
		$3.5 \text{ m} < L \leq 4.2 \text{ m}$	1	$2 \times \phi 5.5$
		$4.2 \text{ m} < L \leq 4.7 \text{ m}$	2	$2 \times \phi 5.5$
		$4.7 \text{ m} < L \leq 6 \text{ m}$	3	$2 \times \phi 5.5$
	Telescopic straight	$L < 3 \text{ m}$	1	$2 \times \phi 4.5$

	boom pole/Curved boom pole	$3\text{ m} \leq L < 3.5\text{ m}$	2	$2 \times \phi 4.5$
		$3.5\text{ m} \leq L \leq 4\text{ m}$	3	$2 \times \phi 4.5$
		$4\text{ m} < L < 5\text{ m}$	1	$2 \times \phi 5.5$
		$5\text{ m} \leq L \leq 6\text{ m}$	2	$2 \times \phi 5.5$

 **NOTE**

If the boom pole length changes, select the spring type again according to the table above, and adjust corresponding parameters.

Chapter 3 Wiring

Refer to the figure below for the wiring of barrier gate.

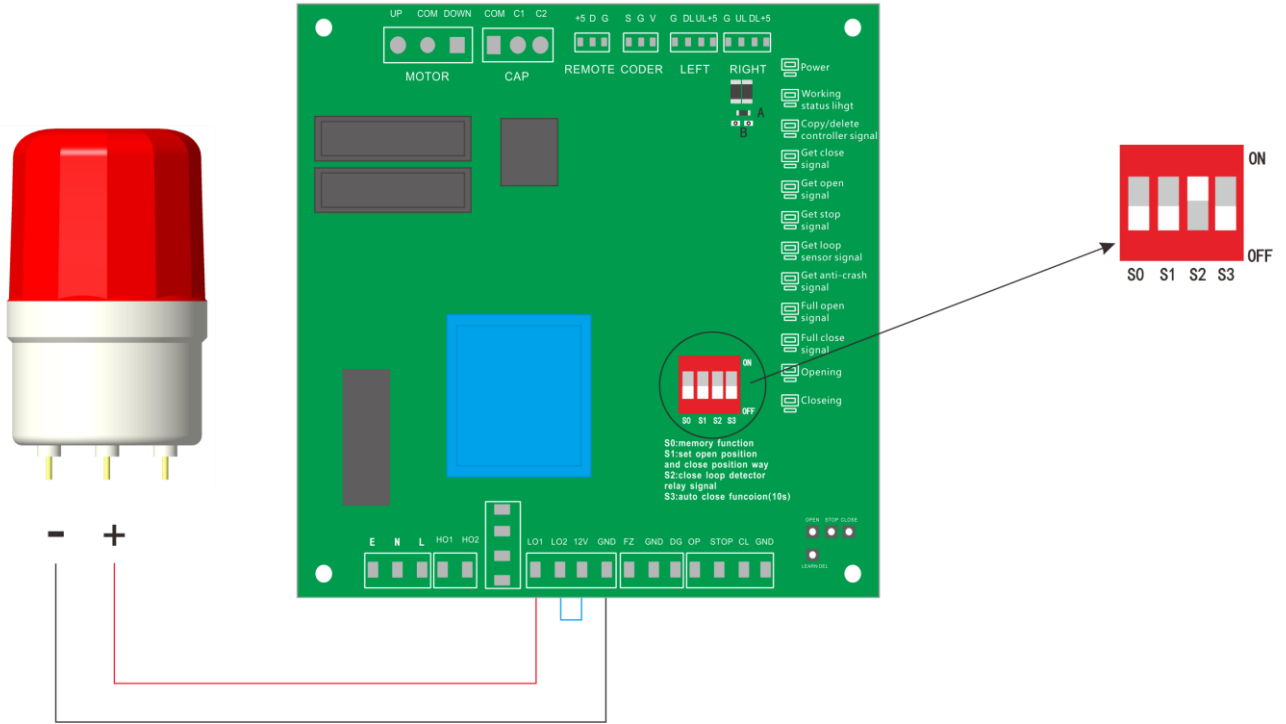

Figure 3-1 Wiring

Chapter 4 Dimension

Refer to the figure below for the dimension of the barrier gate with non-telescopic straight boom pole.

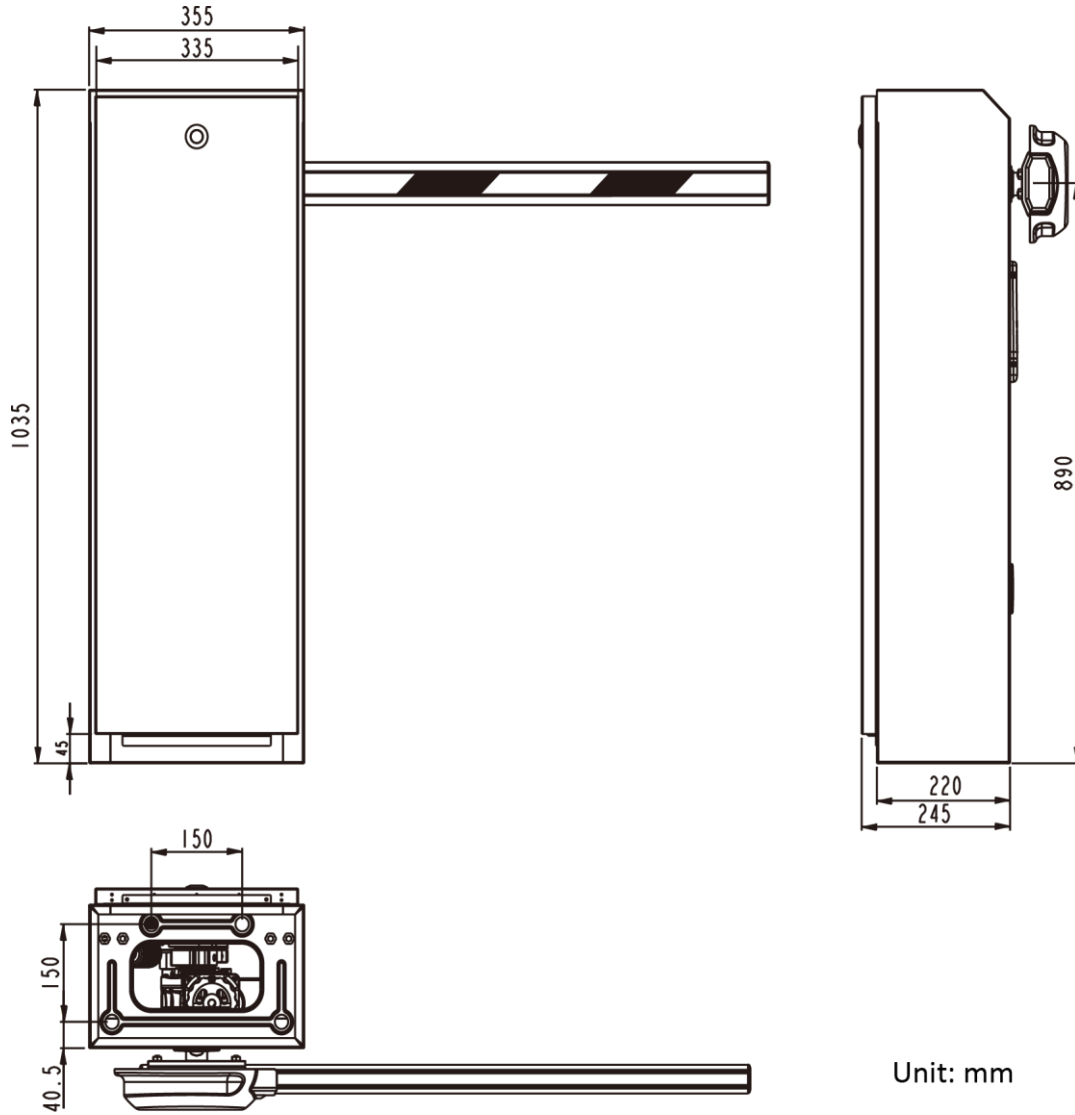

Figure 4-1 Dimension

 **NOTE**

For the barrier gate with telescopic straight boom pole or curved boom pole, the dimensions of the host and base are the same as above.

Chapter 5 Barrier Gate Component

5.1 Barrier Gate with Straight Boom Pole

Refer to the figure and table below for the component description of the barrier gate with straight boom pole.

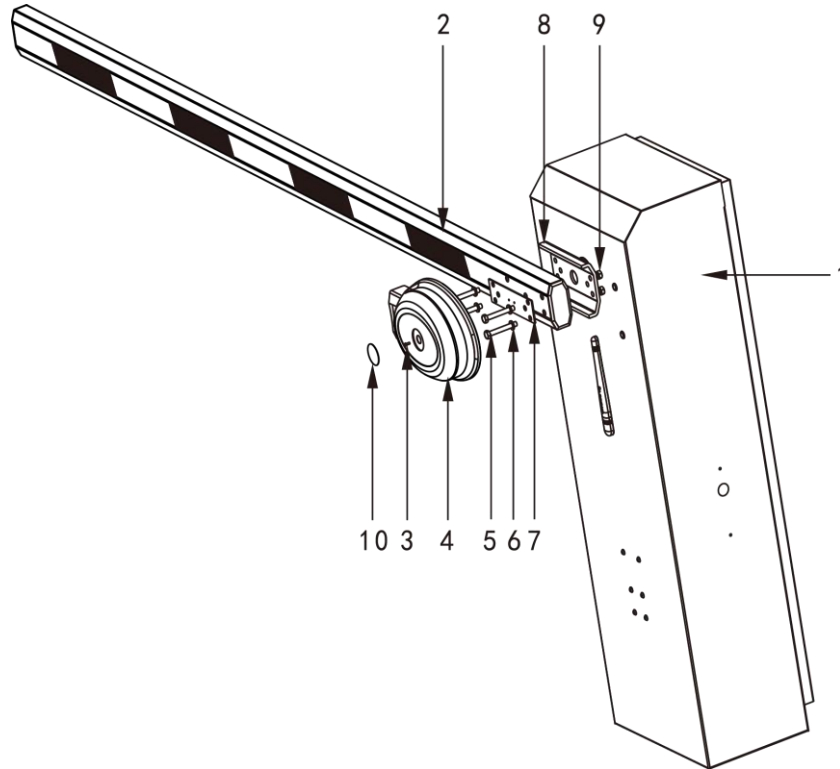

Figure 5-1 Barrier Gate Component (1)

Table 5-1 Barrier Gate Component Description (1)

No.	Name	Quantity
1	Barrier gate host	1
2	Boom pole	1
3	Cross recessed pan head screw M3 × 8	1
4	Boom pole mounting housing	1
5	Hexagon head bolt M8 × 65	4
6	Flat washer φ 8	4
7	Boom pole mounting cushion block	1
8	Main shaft mounting	1
9	Hexagon check nut M8	4
10	Boom pole mounting housing label	1

5.2 Barrier Gate with Curved Boom Pole

Refer to the figure and table below for the component description of the barrier gate with curved boom pole.

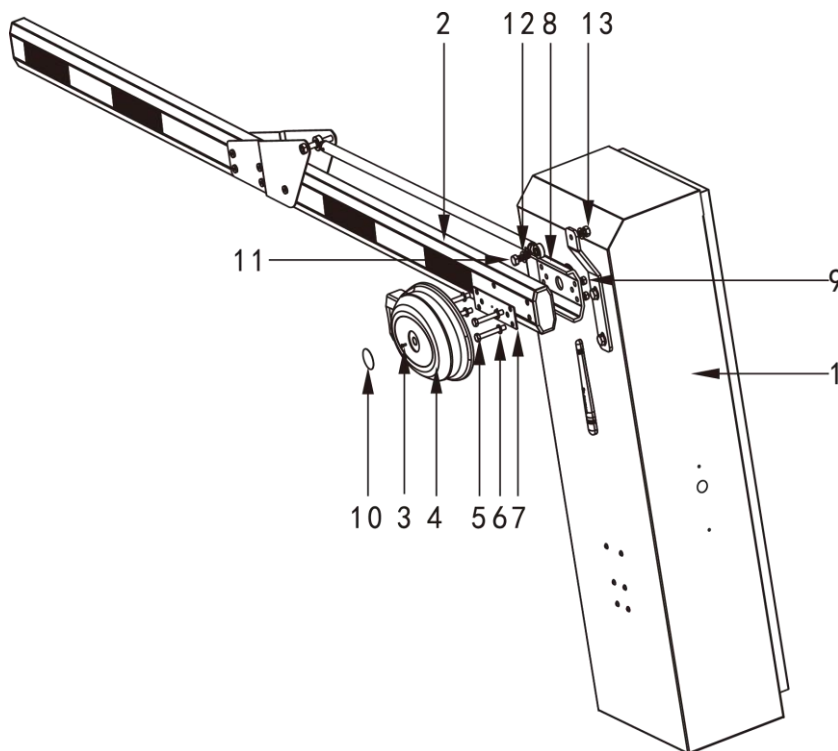

Figure 5-2 Barrier Gate Component (2)

Table 5-2 Barrier Gate Component Description (2)

No.	Name	Quantity
1	Barrier gate host	1
2	Boom pole	1
3	Cross recessed pan head screw M3 × 8	1
4	Boom pole mounting housing	1
5	Hexagon head bolt M8 × 65	4
6	Flat washer φ 8	4
7	Boom pole mounting cushion block	1
8	Main shaft mounting	1
9	Hexagon check nut M8	4
10	Boom pole mounting housing label	1
11	Hexagon head bolt M10 × 30	3
12	Flat washer φ 10	5
13	Hexagon check nut M10	1

Chapter 6 Installation

6.1 Installation Description



Cut off power before installation.

- Open the package, and check the accessories according to the accessory checklist.
- Confirm the installation position of the barrier gate host according to the boom pole direction and the actual condition of the installation site. For the non-concrete foundation or the position with slope, it is recommended to build the concrete foundation first. Make sure the base of the barrier gate host can be fixed firmly on the foundation, and the perpendicularity of the host to the horizontal plane is smaller than 1° .
- Lay power cables and control wires tubes according to corresponding regulations and the position of the control room. It is recommended that the power cables and control wires are laid in different tubes.
- Install expansion screws on the installation position of the host to fix the host firmly.
- Rotate the crank handle to set the boom pole to the horizontal position to confirm the installation position of the support rod at the end of the boom pole, and fix the support rod firmly with screws (Ignore this if there is no support rod).
- Connect the power cables and control wires to the control board of the host according to the wiring diagram. Fasten them and start debug after confirming the connection is correct.

6.2 Installation

Before you start:

Confirm the position to fix the host. Build the concrete foundation if needed. The dimension of the foundation should be approximate 100 to 150 mm larger than that of the host bottom.

Steps:

1. Bury cables.
 - 1) Dig a ditch and bury cable tubes between the center of the host fixed position and the control room.
 - 2) Pass $3 \times 1.5 \text{ mm}^2$ power cables and $4 \times 0.5 \text{ mm}^2$ control wires through the tubes.
 - 3) Fill the ditch with concrete.
2. Fix the host.
 - 1) Put the host on the pre-confirmed position. Open the door, and make marks of the installation holes' centers on the bottom and the host base margins.
 - 2) Remove the host, and punch holes on the marked positions of the screws.

**NOTE**

The drill size should be matched with the attached expansion screw, and the hole depth should meet the requirement of the expansion screw length.

- 3) Put the host on the pre-confirmed position. Punch expansion screws into the bottom holes and fasten them firmly.
3. Install the boom pole.
 - 1) Install the boom pole to the main shaft mounting on the host, and fasten the screws to make sure the boom pole does not tilt.
 - 2) (Optional) If support rod is needed, debug the horizontal and vertical status of the boom pole, rotate the crank handle to set the boom pole to the horizontal position to confirm the installation position of the support rod at the end of the boom pole, and fix the support rod firmly with screws.
4. Install peripheral devices.
 - 1) After the barrier gate installation and debug completes, wire the lines in the host and connect the control lines of the peripheral devices according to the wiring diagram.
 - 2) Debug the devices.

6.3 Installation Debug

Problem	Debug Method
The boom pole is not on the horizontal/vertical position.	<ol style="list-style-type: none"> 1. Unfasten the two screws on the main shaft crank arm, and set the boom pole to the horizontal position. 2. Learn the horizontal limit position, and fasten the screws. 3. Adjust the vertical position of the boom pole to appropriate angle, and learn the vertical limit position.
The boom pole shakes during rising.	The spring is too tight. Adjust the spring holes, or unfasten the adjustment lever to adjust the spring tightness.
The boom pole shakes during falling.	The spring is too loose. Adjust the spring holes, or fasten the adjustment lever to adjust the spring tightness.

Chapter 7 Remote Control

7.1 Button Description

The buttons are on the lower right corner of the control board.

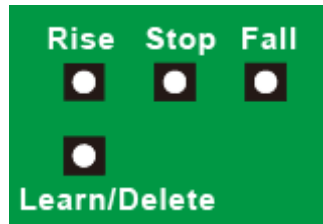

Figure 7-1 Buttons

7.1.1 Independent Button

- Rise: To control the boom pole to rise. Hold it and the boom pole will not fall.
- Stop: To stop the boom pole.
- Fall: To control the boom pole to fall down.
- Learn/Delete: Hold it for three seconds to enter the remote control learning mode, and the status indicator will flash in high frequency. Hold it for five seconds to clear all the learning records.

7.1.2 Button Combination

The triggering sequence of the buttons is from left to right. When you trigger the button on the right, the button on the left should be kept triggering status.

- Learn/Delete + Rise: In manual learning mode, press the buttons to learn rising limit position. In auto learning mode, press the buttons to get the rising limit position, locate the falling limit position and judge the boom pole direction automatically, and calculate the running time of the barrier gate. When the status indicator is flashing in the frequency of 0.1 s, loosen the buttons.
- Learn/Delete + Fall: In manual learning mode, press the buttons to learn falling limit position. In auto learning mode, press the buttons to get the falling limit position, locate the rising limit position and judge the boom pole direction automatically, and calculate the running time of the barrier gate. When the status indicator is flashing in the frequency of 0.1 s, loosen the buttons.
- Learn/Delete + Stop: Press them to enter the auto test status. When the status indicator is flashing in the frequency of 0.1 s, loosen the buttons.

- Stop + Rise + Fall: Press them to switch between hall limit position and angle sensor limit position. If angle sensor limit position is applied, the boom pole has resistance rebound function.

7.2 Dip Switch Description

The dip switch is shown as below. There are four levels of the switch.

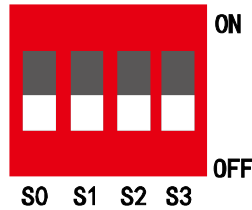

Figure 7-2 Dip Switch

- S0: If it is on, counting function is enabled. If it is off, the counting function is disabled.
- S1: In angle sensor mode, switch it to switch the limit position learning modes. If it is on, it will switch to auto learning mode. If it is off, it will switch to manual learning mode.
- S2: If it is on, the barrier gate will continuously output signal during the rising/falling of the boom pole. If it is off, the barrier gate will output signal after it is at the rising/falling limit position.
- S3: If it is on, delayed boom pole falling is enabled. If it is off, delayed boom pole falling is disabled.

7.3 Limit Position Learning Mode Description

- Manual learning mode: To locate the rising and falling limit positions manually and accurately.
- Auto learning mode: To locate the current position as the rising limit position (or falling limit position), locate the falling limit position (or rising limit position) automatically, and judge the boom pole direction.

NOTE

The barrier gate must be switched to manual learning mode after leaving factory.

7.4 Status Indicator Description

- Normal working status:
 - When you adopt angle sensor limit position, the status indicator will flash in the frequency of 0.5 s. When you adopt hall limit position, the status indicator will be solid.
 - When the delayed boom pole falling is enabled, the status indicator will flash in the

frequency of 0.1 s after the boom pole rises to the limit. Until the boom pole falls to the limit, the status indicator will flash in the frequency of 0.5 s. When the delayed boom pole falling is disabled, the status indicator will flash in the frequency of 0.5 s.

- Remote control learning status: Hold the learn button for three seconds. The status indicator will be on for 250 ms, and then unlit for 250 ms. Then loosen the learn button to register remotely. After the learning succeeded, the indicator will be unlit and then return to the normal working status. If the learn button is kept holding for more than five seconds, it will enter the registration deleting status. The status indicator will flash in the frequency of 0.1 s, indicating it starts to delete the registration code. Then you can loosen the learn button.
- Setting parameters status: Press the valid button combination. The status indicator will flash in the frequency of 0.1 s, indicating you can loosen the buttons.

7.5 Remote Control Debug

After the barrier gate powers on, do the remote control debug.

Steps:

1. Switch S1 on.
2. Learn limit positions automatically.
 - 1) Adjust the boom pole to the rising limit position (or falling limit position) manually.
 - 2) Press **Learn/Delete** and **Rise** buttons (or **Learn/Delete** and **Fall** buttons). Then the boom pole will locate the current position as the rising limit position (or falling limit position), and locate the falling limit position (or rising limit position) automatically.
3. Adjust the limit positions finely.
 - 1) Switch S1 off.
 - 2) Adjust the boom pole to the appropriate rising limit position manually.
 - 3) Press **Learn/Delete** and **Rise** buttons to save the current position as the rising limit position.
 - 4) Adjust the boom pole to the appropriate falling limit position manually.
 - 5) Press **Learn/Delete** and **Fall** buttons to save the current position as the falling limit position.
4. Register remotely. Hold the learn button for three seconds. The status indicator will be on for 250 ms, and then unlit for 250 ms. Loosen the learn button to register remotely.

NOTE

- Learning limit positions automatically must be done when you debug the main board for the first time, or when you change a new main board for the barrier gate. Or the barrier gate may run abnormally, and the main board will beep twice every one second. The beeping duration each time is 0.2 s, and the beeping interval is 0.2 s.
- If the motor fails during the auto learning process, the learning will fail. Enlarge the distance between the rising limit position (or falling limit position) and the mechanical limit position to

ensure the motor can run for more than 0.3 s.

- In angle sensor mode, if exception occurs and the device needs to learn the limit positions again, auto learning must be done firstly.

Chapter 8 Maintenance

- Clear the dirt on the barrier gate surface regularly to keep it clean.
- Check if the fasteners of the device are loose or lost once every month. Fasten them in time.
- Pour lubricant to the connectors every three months to keep them working smoothly.
- Check the balance springs after running for 30,000 times, and adjust the springs balance in time.
- Check if the easily damaged parts are damaged every six months, and change them if necessary.



See Far, Go Further